

ANALOG TO DIGITAL CONVERTER INTERFACING MODULE (ET-ADC-0809)

The ET- ADC-0809 module will demonstrate to the student as to how A to D converter chips can be interfaced to the microprocessor-based system through the I/O lines. It will also help to understand that how an A/D conversion actually takes place and what is the meaning of terms like start of conversion, End of conversion etc.

GENERAL

Excel ET-ADC-0809 A/D module card is an 8-bit analog to digital converter with 8 channel multiplexer and microprocessor compatible control logic.

The heart of the module is ADC-0809 monolithic C-MOS device. Its conversion time is 100 micro sec. It eliminates the need for external zero and full scales adjustment. The card selects one of the eight unipolar inputs, by using the address decoder. ADC uses successive approximation as conversion techniques. Input is latched to the decoder on the low to high transition of the address latch enable signal. The conversion starts on the falling edge of the start of conversion signal. During the process, End of conversion signal goes low, otherwise it remains high. Digital output can be read from ADC making output enable signal high.

All eight inputs of ADC-0809 along with external clock, External EOC, external SOC Signals are brought to 26-pin connector (J2). All control signals and digital output signals of ADC are brought to 26-pin connector (J1). One 8255 PPI along with 8085/8086/8088/8031/8051 can be used to get analog to digital conversion data.

A clock input of a specified frequency is required for the operation of ADC 0809. A counter 741s93 has been used for this purpose. The user can either use internal clock or external clock. For use of internal clock, connect pins 2 & 3 through jumper (JP2) Layout at clock position and also select one of clock, out of four clocks marked by x1, x2, x3, and x4 on the module at JP1 The card is factory set for internal clock.

For using external clock, connect pin 1 & 2 through jumper (JP2) at clock position and also give clock pulse at pin no. 17 of connector (J2).

Similarly start of conversion pulse and End of conversion pulse can be given either by software or by external signal. Connect pins 2 & 3 through jumper (JP4) at SOC to give the software pulse, otherwise connect pins 1 & 2 through jumper (JP4) at SOC to give external SOC pulse at pin no. 21 of connector (J2). The card is factory set for software pulse.

Connect pins 2 & 3 through jumper (JP3) EOC to give software pulse. Otherwise connect pins 1 & 2 through jumper (JP3) at EOC to give external EOC pulse at pin no. 19 of connector (J2). The card is factory set for software pulse.

Connect pins 2 & 3 of jumper (JP5) at Output ENBL to give software pulse. Otherwise connect pin 1 & 2 of jumper (JP5) at ENBL to give external pulse.

ANALOG TO DIGITAL CONVERTER

The module will also display digital data on LED's. The corresponding LED's will glow if the bits are high, otherwise remain off.

A variable voltage source of 0 to +5V is provided on the board of the Module. This can be used by the students to provide the variable voltage to channel 0 of the ADC through jumper JP6. Channel 0 can be either connected to the variable source by selecting the jumper for the INTERNAL source. On the other hand if the students want to give the voltage from the external, connect the jumper towards EXT.

Layout of ET – ADC0809 Module

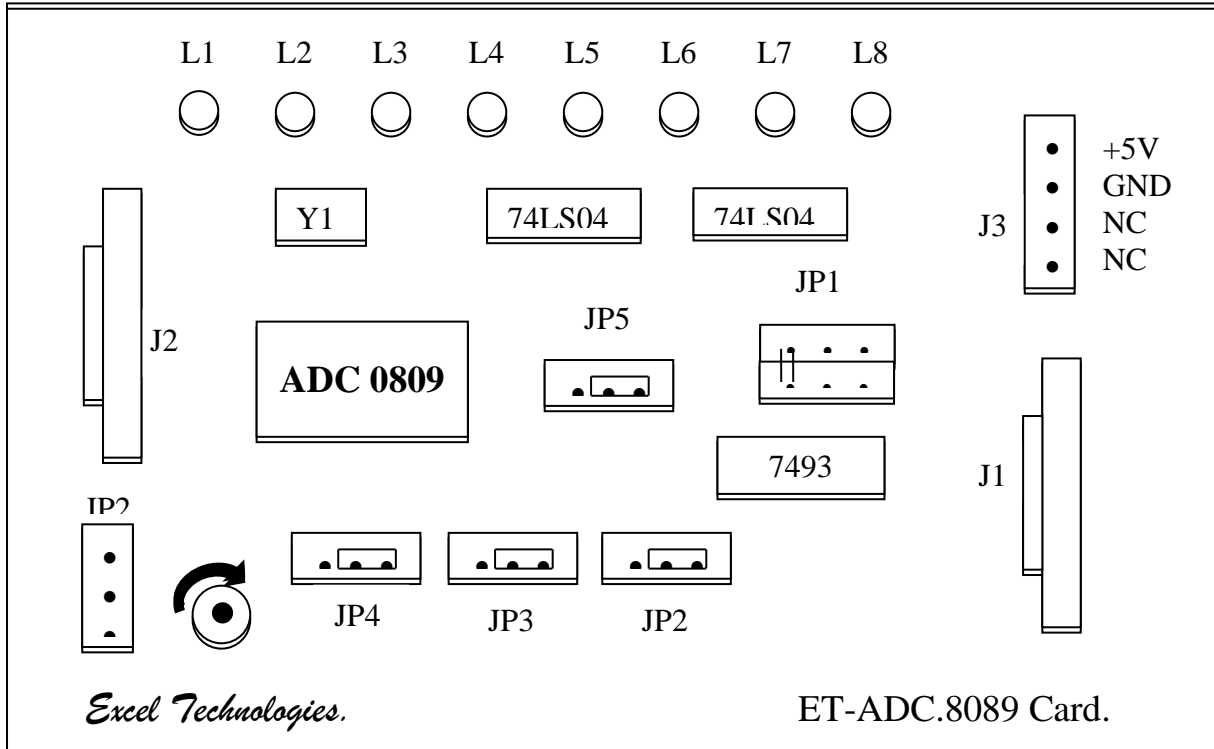

Connector Detail of J2

PIN NO.	CONNECTION DETAILS	PIN NO.	CONNECTION DETAILS
1	CH7 INPUT	14	GND
2	GND	15	CH0 INPUT
3	CH6 INPUT	16	GND
4	GND	17	CLK Through JP2
5	CH5 INPUT	18	GND
6	GND	19	E.O.C. Through JP3
7	CH4 INPUT	20	NC
8	GND	21	S.O.C. Through JP4
9	CH3 INPUT	22	NC
10	GND	23	O/P Enable
11	CH2 INPUT	24	NC

ANALOG TO DIGITAL CONVERTER

12	GND	25	GND
13	CH1 INPUT	26	GND

ANALOG TO DIGITAL CONVERTER -Experiment -1

Write a program to scan channel 0 of the A/D converter and display the digital count corresponding to Analog input on the Display.

SETUP FOR THE EXPERIMENT

This explanation as well as the explanation of the Program under the heading “Description of the Program” is for 8085 LED Kit. However if you are interfacing the Dual DAC Module to other Kits, then also refer to the specific instruction before the program listing for that particular Kit also

- 1) Connect the ET-ADC interfacing module to the 8255-1 port connector of the kit using 26-pin flat FRC cable. The pin No.1 of the connector on the module as well as the kit is marked. Please ensure that the pin no. 1 of the connector is connected to pin no. 1 of the module.
- 2) Connect the +5V,GND to the Module either through the Kit or Externally.
- 3) Enter the program given below from the memory location mentioned in the program.
- 4) Select the jumper JP6 to INT side as marked on the Module (to select the internal voltage source)
- 5) Execute the program.
- 6) The digital data corresponding to the voltage applied to channel 0 is displayed on the Kit display. The 8 LED s also represent the Digital Value. Vary the voltage and see that the value changes.

DESCRIPTION OF THE PROGRAM

The 8255-1is initialized to make port A as input port and port C as output port. If the internal voltage source is not selected then the signal for channel 0 (selected at location 2008) is to be fed at pin 15 of the 26 pin connector on the LHS of the module. However if the internal source is selected then the voltage can be varied by the potentiometer available on the Module. The conversion table for the ADC is as follow:

00.00V	is equal to –00
01.25V	is equal to -3F
02.50V	is equal to –7F
05.00V	is equal to –FF

NOTE: - Listing of program for various models of Microprocessor and Micro controller kits is given below. Please select the model of kit being used before entering the program into the kit.

ANALOG TO DIGITAL CONVERTER

LISTING OF THE PROGRAM FOR ANOLOG TO DIGITAL CONVERTER MODULE (ET-ADC-0809) TO INTERFACE WITH 8085 KIT HAVING LED DISPLAY

ADDRESS	OPCODE	LABEL	MNEMONICS	REMARKS
2000	31 FF 20		LXI SP, 20FF	Initialize 8255 PORTs as PA, PCup :IN. PB, PClow : Out
2003	3E 98		MVI A, 98	
2005	D3 03		OUT 03	
2007	3E 00	LOOP 1:	MVI A, 00	Select channel No.
2009	D3 01		OUT 01	
200B	3E 00		MVI A, 00	ALE & start of conversion
200D	D3 02		OUT 02	
200F	3E 03		MVI A, 03	
2011	D3 02		OUT 02	
2013	3E 00		MVI A, 00	
2015	D3 02		OUT 02	
2017	DB 02	LOOP 2:	IN 02	Check EOC
2019	E6 10		ANI 10	
201B	CA 17 20		JZ LOOP2	
201E	3E 04		MVI A, 04	Output Enable
2020	D3 02		OUT 02	
2022	DB 00		IN 00	Read ADC data
2024	32 F6 27		STA 27F6	
2027	CD 47 03		CALL CLEAR	Clear display
202A	11 00 00		LXI D, 0000	Call DELAY
202D	CD BC 03		CALL DELAY	
2030	CD FA 06		CALL MODDOT	
2033	11 00 00		LXI D 0000	Call DELAY
2036	CD BC 03		CALL DELAY	
2039	C3 07 20		JMP LOOP 1	Repeat

Note: - On executing the program, XX will be displayed on the RHS of the display in the kit. The data XX represents the digital value of the Analog Voltage fed to channel 0 by varying the input voltage using variable pot given at bottom LHS of ADC module. The display of kit will display the corresponding digital value of analog voltage with value as 00 for minimum (0V) & FF for maximum (5V).

LISTING OF THE PROGRAM FOR ANOLOG TO DIGITAL CONVERTER MODULE (ET-ADC-0809) TO INTERFACE WITH 8085 KIT HAVING LCD DISPLAY

Connect the J1 of the Kit to the Module through 26 Pin FRC Cable. Ensure that the pin-1 of the J1 at the Kit end is connected to the pin-1 of the Module

ANALOG TO DIGITAL CONVERTER

connector. Enter the program from address 2000. Execute the program from address 2000.

ADDRESS	OPCODE	LABEL	MNEMONICS	REMARKS
2000	31 FF 20		LXI SP, 20FF	Initialize Stack
2003	CD 4D 0F		CALL 0F4D	
2006	06 0C		MVI B, 0C	Load the no. Of characters to be displayed
2008	21 4D 20		LXI H, 204D	
200B	CD 47 17		CALL 1747	Display
200E	3E 98		MVI A 98	Initialize 8255
2010	D3 03		OUT 03	
2012	3E 00		MVI A 00	Select channel-0
2014	D3 01		OUT 01	
2016	3E 00		MVIA 00	S.O.C
2018	D3 02		OUT 02	
201A	3E 03		MVI A 03	
201C	D3 02		OUT 02	
201E	3E 00		MVI A 00	
2020	D3 02		OUT 02	
2022	DB 02	LOOP2	IN 02	CHECK FOR E.O. C
2024	E6 10		ANI 10	
2026	CA 22 20		JZ LOOP2	
2029	3E 04		MVI A, 04	OUTPUT ENABLE
202B	D3 02		OUT 02	
202D	DB 00		IN 00	READ ADC DATA
202F	21 00 21		LXI H, 2100	TEMPERORY LOCATION FOR DATA
2032	77		MOV M, A	
2033	3E 8D		MVI A, 8D	SELECT LCD POSITION FOR DATA
2035	D3 38		OUT 38	
2037	CD 31 0F		CALL 0F 31	CALL DELAY
203A	CD 31 0F		CALL 0F 31	CALL DELAY
203D	CD 31 0F		CALL 0F 31	CALL DELAY
2040	21 00 21		LXI H 2100	POINT TO DATA
2043	7E		MOV A, M	CALL LIST B
2044	CD 33 11		CALL 1133	
2047	C3 12 20		JMP 2012	LOOP BACK TO CH-0
204A	FF FF FF			
204D	44 49 47 49 54 41 4C 20 44 41 54 41			HEX DATA FOR "DIGITAL DATA".

Note: - On executing the program, the message "DIGITAL DATA XX" will be displayed on the LCD display in the kit. The data XX represents the digital value of the Analog Voltage fed to channel 0 by varying the input voltage using variable pot given at bottom LHS of ADC module.

ANALOG TO DIGITAL CONVERTER

The display of kit will display the corresponding digital value of analog voltage with value as 00 for minimum (0V) & FF for maximum (5V).

LISTING OF THE PROGRAM FOR ANOLOG TO DIGITAL CONVERTER MODULE (ET-ADC-0809) TO INTERFACE WITH 8086 KIT HAVING LED DISPLAY

FOR ET-8086:

Connect the J3 of the Kit to the Module through 26 Pin FRC Cable. Ensure that the pin-1 of the J3 at the Kit end is connected to the pin-1 of the Module connector. Enter the program from address 0000:0200.

FOR ET-8086AD:

Connect the J1 of the Kit to the Module through 26 Pin FRC Cable. Ensure that the pin-1 of the J1 at the Kit end is connected to the pin-1 of the Module connector. Enter the program from address 0000:0200.

This Program will convert the Analog signal fed to Channel 0 of the ADC to the digital value and display the digital value on the LED display of the Kit. The Program is written for connecting the Module to the first 8255 of the Kit. The Channel 0 of the ADC is connected to a variable voltage source once the jumper is selected for int.

ADDRESS	OPCODE	LABEL	MNEMONICS	REMARKS
0000:0100	BC 00 04		MOV SP,0400	Initialize Stack Pointer
0103	B0 98		MOV AL,98	Initialize the 8255 as PA PC _{UP} -INPUT and PB, PC _L -OUT PUT
0105	BA FE FF		MOV DX,FFFE	
0108	EE		OUT DX, AL	
0109	B0 00	YY:	MOV AL,00	
010B	BA FA FF		MOV DX,FFFA	Send 00 to port B & Port C
010E	EE		OUT DX,AL	
010F	BA FC FF		MOV DX,FFFC	
0112	EE		OUT DX,AL	
0113	B0 03		MOV AL,03	ALE
0115	EE		OUT DX, AL	
0116	B0 00		MOV AL,00	SOC
0118	EE		OUT DX,AL	
0119	EC	XX:	IN AL,DX	Check E.O.C.
011A	24 10		AND AL,10	
011C	75 FB		JNZ 011E	
011E	B0 04		MOV AL, 04	Output Enable
0120	EE		OUT DX, AL	
0121	BA F8 FF		MOV DX,FFF8	Read Port A
0124	EC		IN AL,DX	

ANALOG TO DIGITAL CONVERTER

0125	B4 00		MOV AH,00	Display Digital Data
0127	50		PUSH AX	
0128	B0 00		MOV AL,00	
012A	50		PUSH AX	
012B	B0 01		MOV AL,01	
012D	50		PUSH AX	
012E	50		PUSH AX	
012F	9A E0 0B 00 FF		CALL DISPLAY	
0134	BA 40 50	DELAY:	MOV DX,5040	
0137	4A	DELAY1:	DEC DX	
0138	75 FD		JNZ DELAY	
013A	EB CD		JMP 0109	Loop Back

Note: - On executing the program, XX will be displayed on the RHS of the display in the kit. The data XX represents the digital value of the Analog Voltage fed to channel 0 by varying the input voltage using variable pot given at bottom LHS of ADC module. The display of kit will display the corresponding digital value of analog voltage with value as 00 for minimum (0V) & FF for maximum (5V).

LISTING OF THE PROGRAM FOR ANOLOG TO DIGITAL CONVERTER MODULE (ET-ADC-0809) TO INTERFACE WITH 8086 KIT HAVING LCD DISPLAY

FOR - ET-8086LCD

Connect the J2 of the Kit to the Module through 26 Pin FRC Cable. Ensure that the pin-1 of the J2 at the Kit end is connected to the pin-1 of the Module connector. Enter the program from address 1000:0100. Execute the Program from address 1000:0100

FOR - ET-8086 -AD-LCD

Connect the J1 of the Kit to the Module through 26 Pin FRC Cable. Ensure that the pin-1 of the J1 at the Kit end is connected to the pin-1 of the Module connector. Enter the program from address 1000:0100. Execute the Program from address 1000:0100

ADDRESS	OPCODE	LABEL	MNEMONICS	REMARKS
1000:0100	CD AC		INT AC	Clear Display
0102	BE 00 13		MOV SI, 1300	Make software buffer to store value
0105	BC FF 10		MOV SP,10FF	Initialize SP
0108	B0 98		MOV AL,98	Initialize the 8255 as I/O

ANALOG TO DIGITAL CONVERTER

010A	BA 07 88		MOV DX,8807	mode
010D	EE		OUT DX, AL	
010E	B0 00	YY:	MOV AL,00	Send 00 to Port B and Port C
0110	BA 03 88		MOV DX,8803	
0113	EE		OUT DX,AL	
0114	BA 05 88		MOV DX,8805	
0117	EE		OUT DX,AL	
0118	B0 03		MOV AL,03	Start of Conversion and ALE
011A	EE		OUT DX, AL	
011B	B0 00		MOV AL,00	
011D	EE		OUT DX,AL	
011E	EC	XX:	IN AL,DX	Check E.O.C.
011F	24 10		AND AL,10	
0121	75 FB		JNZ 011E	
0123	B0 04		MOV AL, 04	Output Enable
0125	EE		OUT DX, AL	
0126	BA 01 88		MOV DX,8801	Read Data
0129	EC		IN AL,DX	
012A	88 04		MOV [SI],AL	Store Data at 1300 location
012C	8B 14		MOV DX, [SI]	Display Digital Data
012E	B0 02		MOV AL, 02	
0130	CD AE		INT AE	
0132	CD AB		INT AB	
0134	B9 FF FF		MOV CX,FFFF	Delay
0137	CD AA		INT AA	
0139	EB D3		JMP 010E	Loop Back

Note: - On executing the program, the message “DIGITAL DATA XX” will be displayed on the RHS of the LCD display in the kit. The data XX represents the digital value of the Analog Voltage fed to channel 0 by varying the input voltage using variable pot given at bottom LHS of ADC module. The display of kit will display the corresponding digital value of analog voltage with value as 00 for minimum (0V) & FF for maximum (5V).

LISTING OF THE PROGRAM FOR ANOLOG TO DIGITAL CONVERTER MODULE (ET-ADC-0809) TO INTERFACE WITH 8031/51 KIT HAVING LED DISPLAY

Connect the J4 of the Kit to the Module through 26 Pin FRC Cable. Ensure that the pin-1 of the J4 at the Kit end is connected to the pin-1 of the Module connector. Enter the program from address 2000.

ANALOG TO DIGITAL CONVERTER

ADDRESS	CODES	LABEL	MNEMONICS	COMMENTS
2000	74 98	START:	MOV A, #98H	Initialize 8255-I Port B, Cly Out Port A, Cup in.
2002	90 FF 03		MOV DPTR, #FF03H	
2005	F0		MOVX @DPTR, A	
2006	90 20 80		MOV DPTR, #2080H	Write "C"
2009	74 63		MOV A, #63H	
200B	F0		MOVX @DPTR, A	
200C	A3		INC DPTR	Write "H"
200D	74 90		MOVA, #90H	
200F	F0		MOVX @DPTR, A	
2010	A3		INC DPTR	Write "-"
2011	74 FD		MOVA, #FDH	
2013	F0		MOVX @DPTR, A	
2014	90 20 70		MOV DPTR, #2070H	Read channel no.
2017	E0		MOVX A, @DPTR	
2018	90 FF 01		MOV DPTR, #FF01H	Channel select
201B	F0		MOVX @DPTR, A	
201C	12 07 E2		LCALL GETCODE	Write Channel No.
201F	90 20 83		MOV DPTR, #2083H	
2022	F0		MOVX @DPTR, A	
2023	90 FF 02	LOOP2:	MOV DPTR, #FF02H	Send SOC
2026	74 00		MOVA, #00H	
2028	F0		MOVX @DPTR, A	
2029	74 03		MOVA, #03H	
202B	F0		MOVX @DPTR, A	
202C	74 00		MOVA, #00H	
202E	F0		MOVX @DPTR, A	
202F	E0	LOOP1:	MOVX A, @DPTR	Read EOC
2030	54 10		ANL A, #00H	
2032	60 FB		JZ LOOP1	
2034	74 04		MOV A, #04H	Enable output
2036	F0		MOVX @DPTR, A	Send ALE
2037	90 FF 00		MOV DPTR, #FF00H	Read Digital Data
203A	E0		MOVX A, @DPTR	
203B	FA		MOV R2, A	Store in R2
203C	C4		SWAP A	Write MSB nibble
203D	54 0F		ANL A, #0FH	
203F	12 07 E2		LCALL GETCODE	
2042	90 20 84		MOV DPTR, #2084H	
2045	F0		MOVX @DPTR, A	Write LSB nibble
2046	EA		MOV A, R2	
2047	54 0F		ANL A, #0FH	
2049	12 07 E2		LCALL GETCODE	
204C	90 20 85		MOV DPTR, #2085H	
204F	F0		MOVX @DPTR, A	Display ON
2050	90 20 80		MOV DPTR, #2080H	
2053	12 06 F7		LCALL DISPLAY	Small Delay
2056	7B 40		MOV R3, #40H	

ANALOG TO DIGITAL CONVERTER

2058	7C 80	LOOP3:	MOV R4, #80H	
205A	DC FE		DJNZ R4, \$	
205C	DB FA		DJNZ R3, LOOP3	
205E	80 C3		SJMP LOOP2	Continue in loop

Note: - On executing the program, “CH – XX” will be displayed on the display in the kit. The data XX represents the digital value of the Analog Voltage fed to channel 0 by varying the input voltage using variable pot given at bottom LHS of ADC module. The display of kit will display the corresponding digital value of analog voltage with value as 00 for minimum (0V) & FF for maximum (5V).

However, one can select the desired channel of ADC by changing the data at location 2070. Default is Channel-0

ADDRESS	DATA	FOR
2070	00	CHANNEL - 0
	01	CHANNEL - 1
	02	CHANNEL - 2
	03	CHANNEL - 3
	04	CHANNEL - 4
	05	CHANNEL - 5
	06	CHANNEL - 6
	07	CHANNEL - 7

LISTING OF THE PROGRAM FOR ANOLOG TO DIGITAL CONVERTER MODULE (ET-ADC-0809) TO INTERFACE WITH 8031/51 KIT HAVING LCD DISPLAY

Connect the J1 of the Kit to the Module through 26 Pin FRC Cable. Ensure that the pin-1 of the J1 at the Kit end is connected to the pin-1 of the Module connector. Enter the program from address 6000. Execute the Program from address 6000

ADDRESS	CODES	LABEL	MNEMONICS	COMMENTS
6000	74 98		MOVA,#98H	Initialize 8255 -1 as
6002	90 28 0B		MOV DPTR,#280BH	PortA, PortC _{UP} -IN and
6005	F0		MOVX @DPTR,A	PortB, Port C _{LOW} -OUT
6006	90 60 70		MOV DPTR,#6070H	Read channel 00
6009	E0		MOVX A,@DPTR	
600A	FF		MOV R7,A	Store data in R7
600B	90 28 09		MOV DPTR,#2809H	
600E	F0		MOVX @DPTR,A	
600F	90 28 0A		MOV DPTR,#280AH	Send SOC

ANALOG TO DIGITAL CONVERTER

6012	74 00		MOVA,#00H	
6014	F0		MOVX @DPTR,A	
6015	74 03		MOVA,#03H	
6017	F0		MOVX @DPTR,A	
6018	74 00		MOVA,#00H	
601A	F0		MOVX @DPTR,A	
601B	E0	LOOP1:	MOVX A,@DPTR	
601C	54 10		ANLA,#10H	Read EOC
601E	60 FB		JZ FB	
6020	74 04		MOVA,#04H	
6022	F0		MOVX @DPTR,A	Send out put Enable
6023	90 28 08		MOV DPTR,#2808H	
6026	E0		MOVX A,@DPTR	Read digital data & Store in R6
6027	FE		MOV R6,A	
6028	12 06 1D		LCALL 061D	Clear LCD
602B	90 60 50		MOV DPTR,#6050H	
602E	12 06 06		LCALL 0606	Display "CH"
6031	EF		MOVA,R7	
6032	12 05 89		LCALL 0589	Display channel no.
6035	12 01 D5		LCALL 01D5	
6038	EE		MOVA,R6	Display blank space
6039	12 60 55		LCALL 6055H	
603C	79 FF		MOV R1,#FFH	
603E	7A FF		MOV R2,#FFH	Give delay
6040	12 01 14		LCALL 0114	
6043	80 BB		SJMP BB	Loop back
Now Store the program from Address 6050				
6050	20 43 48 03 FF		DB	Data for "", "C", "H"
6055	54 F0		ANLA,#F0	Mark acc lower nibble
6057	C4		SWAP A	Exchange higher & lower nibble of Accumulator
6058	12 05 89		LCALL 0589	Display Acc
605B	EE		MOVA,R6	Load data into Acc
605C	54 0F		ANLA,#0FH	Mark Acc upper nibble
605E	12 05 89		LCALL 0589	Display Acc
6061	22		RET	Return

Note: - On executing the program, the message “CH-0 XX” will be displayed on the LCD display in the kit. The data XX represents the digital value of the Analog Voltage fed to channel 0 by varying the input voltage using variable pot given at bottom LHS of ADC module. The display of kit will display the corresponding digital value of analog voltage with value as 00 for minimum (0V) & FF for maximum (5V).

ANALOG TO DIGITAL CONVERTER

However, one can select the desired channel of ADC by changing the data at location 6070. Default is Channel-0

ADDRESS	DATA	FOR
6070	00	CHANNEL - 0
	01	CHANNEL - 1
	02	CHANNEL - 2
	03	CHANNEL - 3
	04	CHANNEL - 4
	05	CHANNEL - 5
	06	CHANNEL - 6
	07	CHANNEL - 7
