

# NDEX

1.	General Description	2
2.	Layout of ET-DAC Module	2
3.	List of Experiments	3
4.	Setup for Experiment	3
5.	Description of Program	3
<b>6.</b>	<b>Listing of Program for Different Models of Kits</b>	
	8085 based Microprocessor kit with LED Display (X – CHANNEL) Program for saw tooth Waveform	4
	8085 based Microprocessor kit with LED Display (Y – CHANNEL) Program for saw tooth Waveform	5
	8085 based Microprocessor kit with LED Display (X – CHANNEL) Program for Ramp Waveform	6
	8085 based Microprocessor kit with LED Display (X – CHANNEL) Program for Square Waveform	7
	8085 based Microprocessor kit with LCD Display (X – CHANNEL) Program for saw tooth Waveform	7
	8085 based Microprocessor kit with LCD Display (Y – CHANNEL) Program for saw tooth Waveform	8
	8085 based Microprocessor kit with LCD Display (X – CHANNEL) Program for Ramp Waveform	9
	8085 based Microprocessor kit with LCD Display (X – CHANNEL) Program for Square Waveform	10
	8086/8088 based Microprocessor kit with LED Display	10
	8086/8088 based Microprocessor kit with LCD Display	11
	8031/51 based Microcontroller kit with LED Display	12
	8031/51 based Microcontroller kit with LCD Display	13

## DUAL CHANNEL DIGITAL TO ANALOG CONVERTER INTERFACING MODULE (ET-DAC)

This module (ET-DAC) demonstrates to the students as to how a D/A converter chip can be interfaced with the microprocessor chip through I/O lines. It will also help the students to understand the programming involved in the DAC chips.

### GENERAL DESCRIPTION:

DAC 0800 is a monolithic 8-bit high-speed current output digital to analogue converter having settling time of 100 Nsec. It has a full-scale error of +/- 5.4V to +/- 18V. The complete details of DAC chip can be referred to from the data books.

The technique followed here for D/A conversion is that A digital number can be converted to an analogue voltage by selectivity adding voltage, which are proportional to the weight of each binary digit.

Port A & Port B of the 8255 are connected to channel 1 and channel 2 of the DAC Chip. A reference voltage of 8V is generated using 723 and is given to Ref points of the DAC 0800. The standard output voltage will be 7.98V when FF is outputted and will be 0V when 00 is outputted. The output of DAC 0800 is fed to the operational amplifier to get the final output as X out and Y out.

Several interesting waveforms can be generated and observed on oscilloscope.

### Layout of ET- DAC Interfacing Module

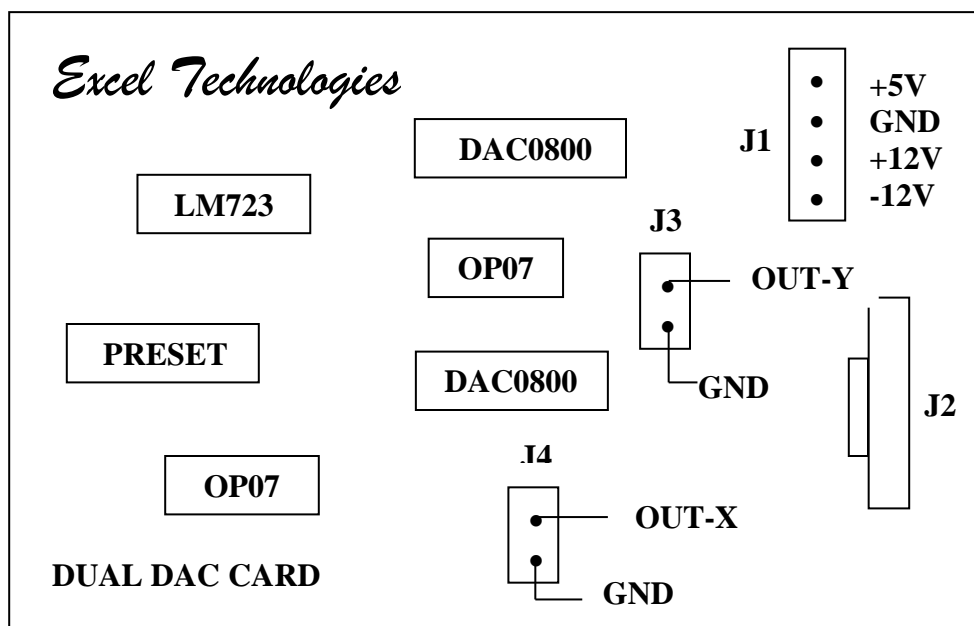

# DUAL CHANNEL DIGITAL TO ANALOGUE CONVERTER

---

## **List of Experiments:**

1. Write a program to generate a stair case with ten steps. The pulse duration should be programmable.
2. Write a program to generate the following wave forms.
  - a) Ramp waveforms.
  - b) Square wave waveform.
3. Write a program to generate sine wave using look up table. The resolution may be chosen at
  - a) 6 Degree,
  - b) 8 Degree.

The frequency of waveform should be programmable.

Software for digital to analogue converter Interface Exercise-1 for channel –1 (X out) is given here. The program generates the staircase and can be seen on oscilloscope.

## **SETUP FOR THE EXPERIMENT**

**This explanation as well as the explanation of the Program under the heading “Description of the Program” is for 8085 LED Kit. However if you are interfacing the Dual DAC Module to other Kits, then also refer to the specific instruction before the program listing for that particular Kit also**

- 1) Connect the ET-DAC interfacing module to the 8255-1 port connector of the kit using 26-pin flat FRC cable. The pin No.1 of the connector on the module as well as the kit is marked. Please ensure that the pin no. 1 of the connector is connected to pin no. 1 of the module.
- 2) Connect the +5V, +12V & -12V to the Module.
- 3) Enter the program given below from the memory location mentioned in the program.
- 4) Execute the program.

## **DESCRIPTION OF THE PROGRAM:**

The 8255 - 1 is initialize to make port A, B and C in output formats. The different weights are put on digital input of D/A converter to generate the analog signal. The program generates the staircase in ten steps. One step is outputted and system waits for a while, and then outputs another weight in input of D/A converter. After the ten steps, the weight of 00 is outputted on D/A converter. The whole process is repeated to generate the repetitive staircase.

## DUAL CHANNEL DIGITAL TO ANALOGUE CONVERTER

---

**NOTE: - Listing of program for various models of Microprocessor and Micro controller kits is given below. Please select the model of kit being used before entering the program into the kit.**

### **1a) PROGRAM FOR GENERATING SAWTOOTH WAVEFORM ON DAC (X-Ch) FOR 8085 KIT WITH LED DISPLAY**

Connect the J1 of the Kit to the Module through 26 Pin FRC Cable. Ensure that the pin-1 of the J1 at the Kit end is connected to the pin-1 of the Module connector. Enter the program from address 2000. Execute the program from address 2000

ADDRESS	OP-CODE	LABEL	MENMONICS	REMARKS
2000	3E 80		MVI A 80	Initialize ports A, B & C as output port.
2002	D3 03		OUT 03	
2004	3E 00	START	MVI A 00	Output the lowest weight on the Input of D/A converter.
2006	D3 00		OUT 00	Output 00
2008	11 20 00		LXI D - 0020	Generate a delay.
200B	CD BC 03		CALL 03BC	
200E	06 00		MVI B 00	Initialize the counter.
2010	DE 19	REP	SBI 19	Subtract 019 to calculate the next weight to be outputted.
2012	D3 00		OUT 00	Output it on port A.
2014	04		INR B	Increment the counter.
2015	FE 0A		CPI 0A	Have all levels over?
2017	CA 27 20		JZ 2027	Z-come to zero level. Else send other level.
201A	F5		PUSH PSW	Save PSW & BC Register pair.
201B	C5		PUSH B	
201C	11 20 00		LXI D - 0020	Generate a delay.
201F	CD BC 03		CALL 03BC	
2022	C1		POP B	Restore Register pair PSW & BC
2023	F1		POP PSW	
2024	C3 10 20		JMP 2010	Repeat outputting Next weight.
2027	3E 00	END	MVI A, 00	Output zero level.
2029	D3 00		OUT 00	
202B	11 20 00		LXI D, 0020	Generate a delay.
202E	CD BC 03		CALL 03BC	
2031	C3 04 20		JMP 2004	Repeat the process.

**Execute the program FROM 2000 and observe the SAWTOOTH WAVEFORM on the oscilloscope at “X-out” pin of the DAC Module.**

## DUAL CHANNEL DIGITAL TO ANALOGUE CONVERTER

---

### **1b) PROGRAM FOR GENERATING SAWTOOTH WAVEFORM ON DAC (Y-Ch) FOR 8085 KIT WITH LED DISPLAY**

The above mentioned exercise has been solved here using a different technique of Look up Table.

Connect the J1 of the Kit to the Module through 26 Pin FRC Cable. Ensure that the pin-1 of the J1 at the Kit end is connected to the pin-1 of the Module connector. Enter the program from address 2000. Execute the program from address 2000

ADDRESS	OP-CODE	LABEL	MENMONICS	REMARKS
2000	3E 80		MVI A 80	Initialize port A, B, C to output
2002	D3 03		OUT 03	
2004	21 28 20	START	LXI H - 2028	Initialize the HL pointer.
2007	0E 08		MVI C 08	Initialize the C, counter
2009	7E	REP	MOV A, M	Load the first weight into ACC.
200A	D3 01		OUT 01	Output it through port B.
200C	E5		PUSH H	Save register pair B and H.
200D	C5		PUSH B	
200E	11 20 00		LXI D - 0020	Generate a delay.
2011	CD BC 03		CALL 03BC	
2014	C1		POP B	Restore registers pair B & H.
2015	E1		POP H	
2016	23		INX H	Increment memory pointer.
2017	0D		DCR C	Decrement counter.
2018	C2 09 20		JNZ 2009	Repeat the process on NZ.
201B	3E 00		MVI A 00	Load lowest weight.
201D	D3 01		OUT 01	
201F	11 00 02		LXI D - 0020	Generate a delay.
2022	CD BC 03		CALL 03BC	
2025	C3 04 20		JMP 2004	Repeat the entire process.

### **LOOK UP TABLE**

ADDRESS	DATA	MNEMONICS	REMARKS
2028	19	DB 19	Weight 1
2029	33	DB 33	Weight 2
202A	4C	DB 4C	Weight 3
202B	66	DB 66	Weight 4

## DUAL CHANNEL DIGITAL TO ANALOGUE CONVERTER

---

202C	7F	DB	7F	Weight 5
202D	99	DB	99	Weight 6
202E	B3	DB	B3	Weight 7
202F	CC	DB	CC	Weight 8
2030	E6	DB	E6	Weight 9
2031	FF	DB	FF	Weight 10

**Execute the program from 2000 and observe the SAWTOOTH WAVEFORM on the oscilloscope at “Y-out” pin of the DAC Module.**

### **1c) PROGRAM FOR RAMP WAVEFORM ON DAC (X-Ch) FOR 8085 KIT WITH LED DISPLAY**

Connect the J1 of the Kit to the Module through 26 Pin FRC Cable. Ensure that the pin-1 of the J1 at the Kit end is connected to the pin-1 of the Module connector. Enter the program from address 2000. Execute the program from address 2000

ADDRESS	OP-CODE	LABEL	MENMONICS	REMARKS
2000	3E 80		MVI A 80	Initialize ports A, B & C as output port.
2002	D3 03		OUT 03	
2004	3E 00		MVI A 00	Output the lowest weight on the Input of D/A converter.
2006	D3 00	LOOP	OUT 00	Output 00
2008	3C		INC A	Generate a delay.
2009	C3 06 20		JUMP LOOP	

**Execute the program from 2000 and observe the RAMP WAVEFORM on the oscilloscope at “X-out” pin of the DAC Module.**

### **1d) PROGRAM FOR SQUARE WAVEFORM ON DAC (X-Ch) FOR 8085 KIT WITH LED DISPLAY**

Connect the J1 of the Kit to the Module through 26 Pin FRC Cable. Ensure that the pin-1 of the J1 at the Kit end is connected to the pin-1 of the Module connector. Enter the program from address 2000. Execute the program from address 2000

ADDRESS	OP-CODE	LABEL	MENMONICS	REMARKS
2000	3E 80		MVI A 80	Initialize ports A, B & C as

## DUAL CHANNEL DIGITAL TO ANALOGUE CONVERTER

2002	D3 03		OUT 03	output port.
2004	3E 00	START	MVI A 00	Output the lowest weight on the Input of D/A converter.
2006	D3 00		OUT 00	Output LOGIC 0
2008	11 F6 00		LXI D F600	Generate a delay.
200B	CD BC 03		CALL DELAY	
200E	3E FF		MVI A FF	
2010	D3 00		OUT FF	OUTPUT LOGIC HIGH
2012	11 F6 00		LXI D F600	
2015	CD BC 03		CALL DELAY	Generate a Delay
2018	C3 04 20		JMP START	LOOP BACK TO START

**Execute the program from 2000 and observe the SQUARE WAVEFORM on the oscilloscope at “X-out” pin of the DAC Module.**

### **2a) PROGRAM FOR GENERATING SAWTOOTH WAVEFORM ON DAC (X-Ch) FOR 8085 KIT WITH LCD DISPLAY**

Connect the J1 of the Kit to the Module through 26 Pin FRC Cable. Ensure that the pin-1 of the J1 at the Kit end is connected to the pin-1 of the Module connector. Enter the program from address 2000. Execute the program from address 2000.

ADDRESS	OP-CODE	LABEL	MENMONICS	REMARKS
2000	3E 80		MVI A 80	Initialize ports A, B & C as output port.
2002	D3 03		OUT 03	
2004	3E 00	START	MVI A 00	Output the lowest weight on the Input of D/A converter.
2006	D3 00		OUT 00	Generate a delay.
2008	11 20 00		LXI D - 0020	
200B	CD A6 03		CALL 03A6	
200E	06 00		MVI B 00	Initialize the counter.
2010	DE 19	REP	SBI 19	Subtract 019 to calculate the next weight to be outputted.
2012	D3 00		OUT 00	Output it on port A.
2014	04		INR B	Increment the counter.
2015	FE 0A		CPI 0A	Have all levels over?
2017	CA 27 20		JZ 2027	Z-come to zero level. Else send other level.
201A	F5		PUSH PSW	Save PSW & BC Register pair.
201B	C5		PUSH B	
201C	11 20 00		LXI D - 0020	Generate a delay.
201F	CD A6 03		CALL 03A6	
2022	C1		POP B	Restore Register pair PSW & BC
2023	F1		POP PSW	

## DUAL CHANNEL DIGITAL TO ANALOGUE CONVERTER

2024	C3 10 20		JMP 2010	Jump to repeat by outputting Next weight.
2027	3E 00	END	MVI A 00	Output zero level.
2029	D3 00		OUT 00	
202B	11 20 00		LXI D - 0020	Generate a delay.
202E	CD A6 03		CALL 03A6	
2031	C3 04 20		JMP 2004	Repeat the process.

**NOTE: - Execute the program from 2000 and observe the RAMP on the oscilloscope at “X-out” pin of the DAC Module.**

### **2b) PROGRAM FOR GENERATING SAWTOOTH WAVEFORM ON DAC (Y-Ch) FOR 8085 KIT WITH LCD DISPLAY**

The above mentioned exercise has been solved here using a different technique of Look up Table.

Connect the J1 of the Kit to the Module through 26 Pin FRC Cable. Ensure that the pin-1 of the J1 at the Kit end is connected to the pin-1 of the Module connector. Enter the program from address 2000. Execute the program from address 2000.

ADDRESS	OP-CODE	LABEL	MENMONICS	REMARKS
2000	3E 80		MVI A 80	Initialize port A, B, C to output
2002	D3 03		OUT 03	
2004	21 28 20	START	LXI H - 2028	Initialize the HL pointer.
2007	0E 08		MVI C 08	Initialize the C, counter
2009	7E	REP	MOV A, M	Load the first weight into ACC.
200A	D3 01		OUT 01	Output it through port B.
200C	E5		PUSH H	Save register pair B and H.
200D	C5		PUSH B	
200E	11 20 00		LXI D - 0020	Generate a delay.
2011	CD A6 03		CALL 03A6	
2014	C1		POP B	Restore registers pair B & H.
2015	E1		POP H	
2016	23		INX H	Increment memory pointer.
2017	0D		DCR C	Decrement counter.
2018	C2 09 20		JNZ 2009	Repeat the process on NZ.
201B	3E 00		MVI A 00	Load lowest weight.
201D	D3 01		OUT 01	

## DUAL CHANNEL DIGITAL TO ANALOGUE CONVERTER

---

201F	11 00 02		LXI D - 0020	Generate a delay.
2022	CD A6 03		CALL 03A6	
2025	C3 04 20		JMP 2004	Repeat the entire process.

### LOOK UP TABLE

ADDRESS	DATA	MNEMONICS	REMARKS
2028	19	DB 19	Weight 1
2029	33	DB 33	Weight 2
202A	4C	DB 4C	Weight 3
202B	66	DB 66	Weight 4
202C	7F	DB 7F	Weight 5
202D	99	DB 99	Weight 6
202E	B3	DB B3	Weight 7
202F	CC	DB CC	Weight 8
2030	E6	DB E6	Weight 9
2031	FF	DB FF	Weight 10

**NOTE:** - Execute the program from 2000 and observe the **SAWTOOTH WAVEFORM** on the oscilloscope at “Y-out” pin of the DAC Module.

### 2c) PROGRAM FOR RAMP WAVEFORM ON DAC (X-Ch) FOR 8085 KIT WITH LCD DISPLAY

Connect the J1 of the Kit to the Module through 26 Pin FRC Cable. Ensure that the pin-1 of the J1 at the Kit end is connected to the pin-1 of the Module connector. Enter the program from address 2000. Execute the program from address 2000

ADDRESS	OP-CODE	LABEL	MENMONICS	REMARKS
2000	3E 80		MVI A 80	Initialize ports A, B & C as output port.
2002	D3 03		OUT 03	
2004	3E 00		MVI A 00	Output the lowest weight on the Input of D/A converter.
2006	D3 00	LOOP	OUT 00	Output 00
2008	3C		INC A	Generate a delay.
2009	C3 06 20		JUMP LOOP	

---

## DUAL CHANNEL DIGITAL TO ANALOGUE CONVERTER

---

**Execute the program from 2000 and observe the RAMP WAVEFORM on the oscilloscope at “X-out” pin of the DAC Module.**

### **2d) PROGRAM FOR SQUARE WAVEFORM ON DAC (X-Ch) FOR 8085 KIT WITH LCD DISPLAY**

Connect the J1 of the Kit to the Module through 26 Pin FRC Cable. Ensure that the pin-1 of the J1 at the Kit end is connected to the pin-1 of the Module connector. Enter the program from address 2000. Execute the program from address 2000

ADDRESS	OP-CODE	LABEL	MENMONICS	REMARKS
2000	3E 80		MVI A 80	Initialize ports A, B & C as output port.
2002	D3 03		OUT 03	
2004	3E 00	START	MVI A 00	Output the lowest weight on the Input of D/A converter.
2006	D3 00		OUT 00	Output LOGIC 0
2008	11 F6 00		LXI D F600	Generate a delay.
200B	CDA6 03		CALL DELAY	
200E	3E FF		MVI A FF	
2010	D3 00		OUT FF	OUTPUT LOGIC HIGH
2012	11 F6 00		LXI D F600	
2015	CD A6 03		CALL DELAY	Generate a Delay
2018	C3 04 20		JMP START	LOOP BACK TO START

**Execute the program from 2000 and observe the SQUARE WAVEFORM on the oscilloscope at “X-out” pin of the DAC Module.**

### **3) PROGRAM FOR DAC (X-Ch) FOR 8086 KIT WITH LED DISPLAY**

#### **FOR ET-8086:**

Connect the J3 of the Kit to the Module through 26 Pin FRC Cable. Ensure that the pin-1 of the J3 at the Kit end is connected to the pin-1 of the Module connector. Enter the program from address 0000:0200.

#### **FOR ET-8086AD:**

Connect the J1 of the Kit to the Module through 26 Pin FRC Cable. Ensure that the pin-1 of the J1 at the Kit end is connected to the pin-1 of the Module connector. Enter the program from address 0000:0200.

## DUAL CHANNEL DIGITAL TO ANALOGUE CONVERTER

---

ADDRESS	OPCODE	LABEL	MNEMONICS	REMARKS
0000:0200	BA FE FF		MOV DX, FFFE	Initialize All Ports of 8255-1 as Output Ports
0203	B0 80		MOV AL, 80	
0205	EE		OUT DX ,AL	
0206	B0 00		MOV AL, 00	Output 00 to port.
0208	BA <b>F8</b> FF		MOV DX, FFF8	<b>X=F8, Y=FA</b>
020B	EE	LOOP	OUT DX ,AL	
020C	FE C0		INC AL	Take next value
020E	EB FB		JMP 020B	

**Note: -**

1. For outputting to the Y-Channel change the content of the program at location 0209 to FA from F8.
2. Execute the program and observe the **TRIANGULAR WAVEFORM** on the oscilloscope at X-out /Y-out pin of the DAC Module.

### 4) PROGRAM FOR DAC (X-Ch) FOR 8086 KIT WITH LCD DISPLAY

#### FOR - ET-8086LCD

Connect the J2 of the Kit to the Module through 26 Pin FRC Cable. Ensure that the pin-1 of the J2 at the Kit end is connected to the pin-1 of the Module connector. Enter the program from address 1000:0100. Execute the Program from address 1000:0100

#### FOR - ET-8086 -AD-LCD

Connect the J1 of the Kit to the Module through 26 Pin FRC Cable. Ensure that the pin-1 of the J1 at the Kit end is connected to the pin-1 of the Module connector. Enter the program from address 1000:0100. Execute the Program from address 1000:0100

ADDRESS	OP-CODE	LABEL	MNEMONICS	REMARKS
1000:0100	BA 07 88		MOV DX, 8807	Initialize All Ports of 8255-1 as Output Ports
0103	B0 80		MOV AL, 80	
0105	EE		OUT DX, AL	
0106	B0 00		MOV AL, 00	Output 00 to port.
0108	BA <b>01</b> 88		MOV DX, 8801	<b>X=01, Y=03</b>
010B	EE	LOOP	OUT DX, AL	
010C	FE C0		INC AL	Take next value
010E	EB FB		JMP 010B	

## DUAL CHANNEL DIGITAL TO ANALOGUE CONVERTER

---

**Note:**

1. For outputting to the Y-Channel change the content of the program at location 0109 to 03 from 01.
2. Execute the program and observe the **TRIANGULAR WAVEFORM** on the oscilloscope at X-out /Y-out pin of the DAC Module.

### 5) PROGRAM FOR DAC(X-Ch) FOR 8031/8051 KIT WITH LED DISPLAY

Connect the J1 of the Kit to the Module through 26 Pin FRC Cable. Ensure that the pin-1 of the J1 at the Kit end is connected to the pin-1 of the Module connector. Enter the program from address 2000.

ADDRESS	OP-CODE	LABEL	MNEMONICS	REMARKS
2000	90 FF 03	START	MOV DPTR, # FF03	Use 8255-I All ports as o/p
2003	74 80		MOVA, # 80	
2005	F0		MOVX @DPTR, A	
2006	74 00		MOVA, # 00	Clear channel -X
2008	90 FF 00		MOV DPTR, # FF00	
200B	F0		MOVX @DPTR, A	
200C	A3		INC DPTR	Clear channel -Y
200D	F0		MOVX @DPTR, A	
200E	F9		MOV R1, A	Clear Register R1
200F	7A FF	REP	MOV R2, # FF	Read channel enable
2011	7B 0A		MOV R3, # 0A	
2013	90 20 50	REP-1	MOV DPTR, # 2050	
2016	E0		MOVX A, @DPTR	Check for Channel -X
2017	F8	CH_X	MOV R0, A	
2018	C4		SWAP A	
2019	54 0F		ANL A, # 0F	
201B	60 08		JZ 08	
201D	E9		MOVA, R1	Out ramp at Channel -X
201E	90 FF 00		MOV DPTR, # FF00	
2021	F0		MOVX @DPTR, A	
2022	24 19		ADD A, #19	
2024	F9		MOV R1, A	
2025	E8	CH_Y	MOV A, R0	Check for Channel -Y
2026	54 0F		ANL A, # 0F	
2028	60 09		JZ 09	

## DUAL CHANNEL DIGITAL TO ANALOGUE CONVERTER

202A	90 FF 01		MOV DPTR, # FF01	Out ramp at Cannel – Y
202D	EA		MOV A, R2	
202E	F0		MOVX @DPTR, A	
202F	C3		CLR C	Clear borrow
2030	94 19		SUBB A, #19	
2032	FA		MOV R2, A	
2033	11 39	DEL	ACALL 2039	Call Delay
2035	DB DC		DJNZ R3, DC	
2037	80 D6		SJMP D6	Continue in loop
2039	90 20 51	DELAY	MOV DPTR, # 2051	Read slope
203C	E0		MOVX A, @DPTR	
203D	F4		CPL A	Invert the slope
203E	FC		MOV R4, A	
203F	DC FE		DJNZ R4, FE	
2041	22		RET	Back to main program.

**Now enter the data at 2050 location to select the channel of the DAC you want to use.**

ADDRESS	CH -X	CH -Y	REMARKS
<b>2050</b>	0	0	BOTH CHANNEL DISABLE
	1	0	<b>CH -X ON</b> CH-Y OFF
	0	1	CH-X OFF <b>CH-Y ON</b>
	1	1	<b>BOTH CHANNEL ON</b>
<b>2051</b>	<b>01-FF</b>		SLOPE OF Waveform CAN BE VARRIED BY PUTTING DATA FROM <b>01-FF</b> .

**Execute the program and observe the SAWTOOTH Waveform on the oscilloscope at X-out /Y-out pin of the DAC Module.**

**NOTE: -The data at location 2051 will decide the slope of the Waveform.**

### **6) PROGRAM FOR 8031/51 KIT HAVING LCD DISPLAY:**

Connect the J1 of the Kit to the Module through 26 Pin FRC Cable. Ensure that the pin-1 of the J1 at the Kit end is connected to the pin-1 of the Module connector. Enter the program from address 6000. Execute the Program from address 6000

ADDRESS	OP-CODE	LABEL	MNEMONICS	REMARKS
6000	90 28 0B	START	MOV DPTR,# 280B	Initialize 8255-1 as all ports output port
6003	74 80		MOVA,#80	

## DUAL CHANNEL DIGITAL TO ANALOGUE CONVERTER

6005	F0		MOVX @DPTR,A	
6006	74 00		MOVA,#00	
6008	90 28 08		MOV DPTR,#2808	Clear Channel - X
600B	F0		MOVX @DPTR,A	
600C	A3		INC DPTR	Clear Channel - Y
600D	F0		MOVX @DPTR,A	
600E	F9		MOV R1,A	Clear Reg R1
600F	7A FF	REP	MOV R2,#FF	Load 255 in R2
6011	7B 0A		MOV R3,#0A	Load 10 decimal in R3
6013	90 60 50	REP-1	MOV DPTR,#6050	Read channel enable
6016	E0		MOVX A,@DPTR	
6017	F8	CH_X	MOV R0,A	Check for
6018	C4		SWAP A	Scrap the nibbles.
6019	54 0F		ANLA,#0F	Mask lower nibbles.
601B	60 08		JZ 08	If zero, jump to CH -Y
601D	E9		MOVA,R1	Out ramp at CH - X
601E	90 28 08		MOV DPTR,#2808	
6021	F0		MOVX @DPTR,A	
6022	24 19		ADD A,#19	Add 19 to Acc and
6024	F9		MOV R1,A	Store in R1

6025	E8	CH_Y	MOV A,R0	Check for CH - Y
6026	54 0F		ANLA,#0F	Mask lower nibbles.
6028	60 09		JZ 09	If zero jump to DEL
602A	90 28 09		MOV DPTR,#2809	Out ramp at CH - Y
602D	EA		MOVA,R2	
602E	F0		MOVX @DPTR,A	
602F	C3		CLR C	Clear borrow
6030	94 19		SUBB A, #19	Subtract 19 A from Acc and store in R2
6032	FA		MOV R2,A	
6033	11 39	DEL	ACALL 6039	Wait for a while
6035	DB DC		DJNZ R3,DC	Decrement R3; jump to REP1 if not zero.
6037	80 D6		SJMP D6	Continue in loop
6039	90 60 51	DELAY	MOV DPTR,#6051	Read slope
603C	E0		MOVX A,@DPTR	
603D	F4		CPLA	Invert the slope
603E	FC		MOV R4,A	
603F	DC FE		DJNZ R4,FE	
6041	22		RET	Back to main program.

**Now enter the data at 6050 location to select the channel of the DAC you want to use.**

## DUAL CHANNEL DIGITAL TO ANALOGUE CONVERTER

---

ADDRESS	CH -X	CH -Y	REMARKS
<b>6050</b>	0	0	BOTH CHANNEL DISABLE
	1	0	<b>CH - X ON CH - Y OFF</b>
	0	1	<b>CH - X OFF CH - Y ON</b>
	1	1	<b>BOTH CHANNEL ON</b>
<b>6051</b>	<b>01-FF</b>		SLOPE OF Waveform CAN BE VARRIED BY PUTTING DATA FROM <b>01-FF</b> .

**Execute the program and observe the SAWTOOTH Waveform on the oscilloscope at X-out /Y-out pin of the DAC Module.**

**NOTE: -The data at location 6051 will decide the slope of the Ramp.**

\*\*\*\*\*